

Zugspannzangenfutter Typ FNH-AZ



Merkmale:

- Sicheres Spannen von Stangen- und Wellenteilen
- Schnellwechsel der Spannzangen mit Wechsellvorrichtung
- Wechsellvorrichtung manuell oder pneumatisch
- Höchste Genauigkeit durch direkte Aufnahme der Spannzangen im Futterkörper
- Stabiler Axialanschlag für Wellenteile
- Voller Durchgang verfügbar durch schnellwechselbaren Anschlag
- Werkstückspezifische Axialanschläge auf Anfrage lieferbar
- Schlanke Ausführung

Zylindrische Spindelaufnahme

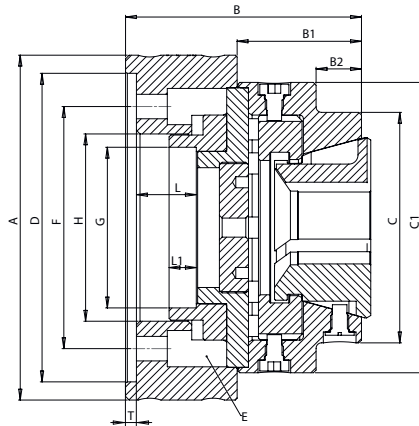

Futter in geöffneter Stellung = Rechte Endposition

Spindelaufnahme	Zyl. 140		Zyl. 170		Zyl. 220	ASA 2-4	
Spannkopfgrösse	Gr. 42	Gr. 52	Gr. 52	Gr. 65	Gr. 80		Gr. 42
Durchlass Rund \varnothing	4-42	4-52	4-52	4-65	10-80		4-42
Durchlass 4 Kt	8-30	8-40	8-40	8-46	10-56		8-30
Durchlass 6 Kt	8-32	8-42	8-42	8-50	10-56		8-32
Futtertyp	FNH-AZ-42-Z140	FNH-AZ-52-Z140	FNH-AZ-52-Z170	FNH-AZ-65-Z170	FNH-AZ-80-Z220	FNH-AZ-42-A4	FNH-AZ-42-A5
Bestellnummer	112-430	112-534	112-535	112-660	112-811	112-427	112-428

Abmessungen

A	160	180	190		240	140	
B	115	139	130		142.5	125	120
B1	58.5	68.5	68.5		77.5		
B2	20	25				20	
C	105		127		150	105	
C1	140		160		180		
D	140 H6		170 H6		220 H6		
E Für Schrauben	6 x M10		6 x M12		6 x M16		
F	104.8		133.4		171.4	82.6	104.8
G	M70 x 1.5	M76 x 1.5	M76 x 1.5	M90 x 1.5	M110 x 2	M70 x 1.5	
H	83	80	103.2		131	61	
L	28	42	33		42.25	44	39
L1			15				
T			6				
max. Drehzahl U/min	7000	6000		5500		7000	
max. Betätigungskraft daN	3500	4000		4500	5000	3500	
max. Spannkraft daN	8000	9600		10500	11500	8000	
empfohlener Spannzylinder	VNK 102-46	VNK 130-67		VNK 150-67	VNK 200-86	VNK 102-46	
Drehzahl U/min	7000	6300		5500	4500	7000	

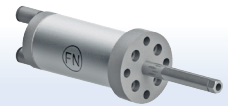
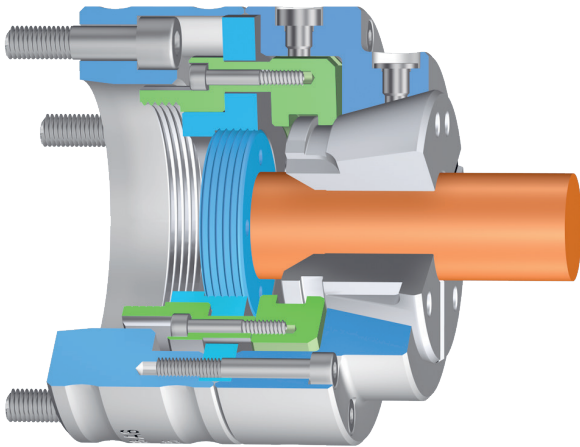

Ausstosser
Seite 185

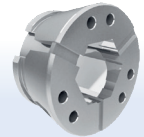

Spannköpfe
Seite 187

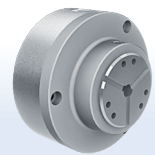

für manuelle
Ausführung sehen
Sie im Kapitel
„FN-Spannzangen-
futter manuell“ nach.

Kegel-Spindelaufnahme

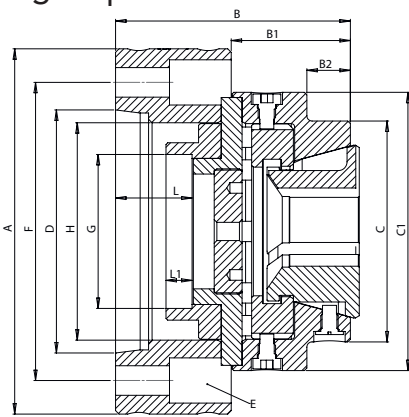

Futter in geöffneten Stellung = Rechte Endposition

ASA 2-5			ASA 2-6			ASA 2-8		
Gr. 52	Gr. 65	Gr. 42	Gr. 52	Gr. 65	Gr. 80	Gr. 52	Gr. 65	Gr. 80
4-52	4-65	4-42	4-52	4-65	10-80	4-52	4-65	10-80
8-40	8-46	8-30	8-40	8-46	10-56	8-40	8-46	10-56
8-42	8-50	8-32	8-42	8-50	10-56	8-42	8-50	10-56
FNH-AZ-52-A5	FNH-AZ-65-A5	FNH-AZ-42-A6	FNH-AZ-52-A6	FNH-AZ-65-A6	FNH-AZ-80-A6	FNH-AZ-52-A8	FNH-AZ-65-A8	FNH-AZ-80-A8
112-531	112-654	112-429	112-532	112-655	112-813	112-533	112-659	112-813
150		160			180		210	
139	140	125	130		155	135		142.5
68.5		58.5	68.5	-		68.5		77.5
25		20			25			
	127		105		127		105	127
140	-		140		-	150	105	127
					180	140	160	180
					-			
6 × M10			6 × M12			6 × M16		
		133.4				171.4		
M76 × 1.5	M90 × 1.5	M70 × 1.5	M76 × 1.5	M90 × 1.5	M110 × 2	M76 × 1.5	M90 × 1.5	M110 × 2
79.6		82		103.2		104	125	131
48	49	44	39		54.75	44		42.25
			15					
6000	7000	6000	5500	6000	5500	6000	5500	5500
4000	4500	3500	4000	4500	5000	4000	4500	5000
9600	10500	8000	9600	10500	11500	9600	10500	11500
VNK 130-67	VNK 150-67	VNK 102-46	VNK 130-67	VNK 150-67	VNK 200-86	VNK 130-67	VNK 150-67	VNK 200-86
6300	5500	7000	6300	5500	4500	6300	5500	4500